

SINK DESCRIPTION

- Manufactured of 22 gauge, type 301 nickel-bearing stainless steel
- Bowl is 12" x 10" x 5"
- The sink ledge has two fixture mounting holes, 1-1/4" in diameter and 4" on center
- Has one 2" diameter recessed drain opening
- Is fully undercoated with a sound and temperature insulating material
- The exposed surfaces are polished to a lustrous satin tone finish
- Includes all necessary mounting hardware

CUT OUT DIMENSIONS

- Cut out dimensions are 14-3/8" x 14-3/8", with a 3/8" corner radius. A tolerance of plus or minus 1/16" is acceptable

STANDARDS

- Third party certified by IAPMO to meet ASME A112.19.3 and all applicable specifications referenced therein. Also meets applicable requirements of ANSI A117.1

WARRANTY

- Warranted for five years against material or manufacturing defects

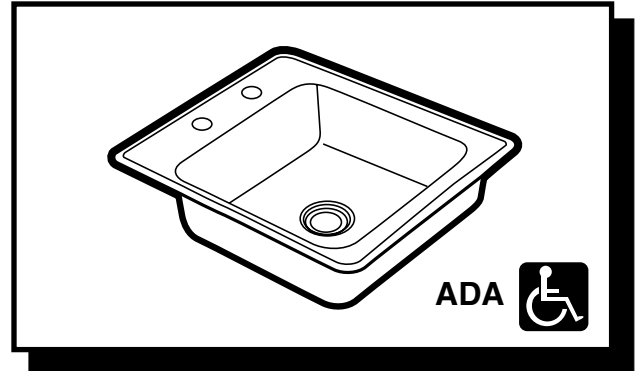

Excalibur®
Single Bowl Bar Sink
Model: 22851
(E-1515-2-2)

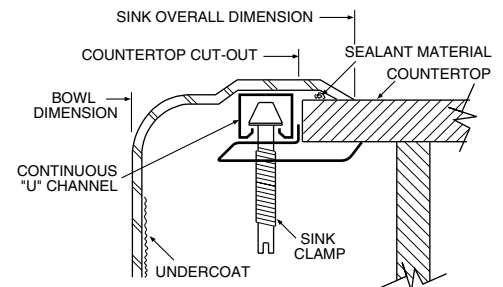

Installation Detail

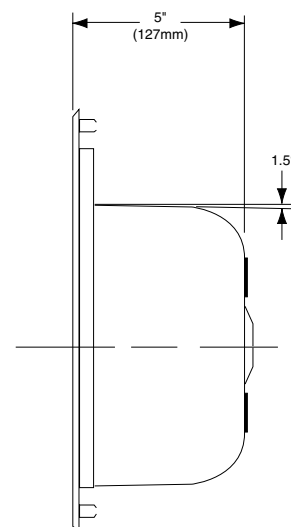
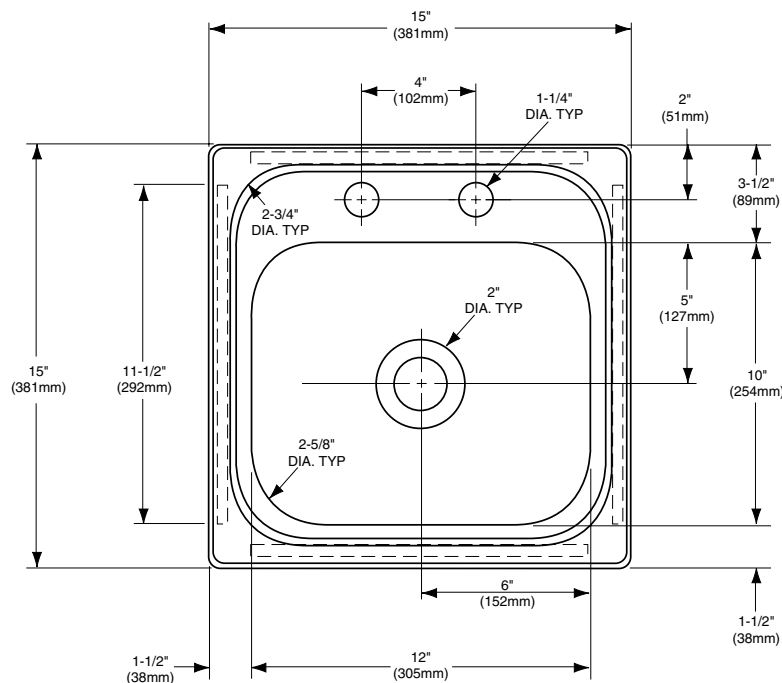

CRITICAL DIMENSIONS

(DO NOT SCALE)